



HELIO THERM HEAT PUMPS

TECHNICAL DATA SHEETS

**Air Source Heat Pump-Split Design
Basic Comfort Series**



DIMENSIONS

Air Source Heat Pump-Split Design | Basic Comfort Series

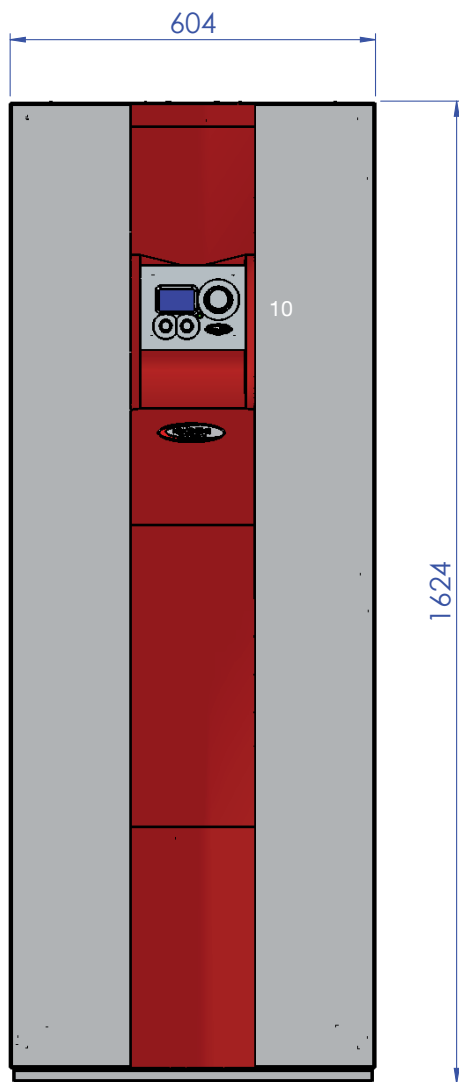

Front view

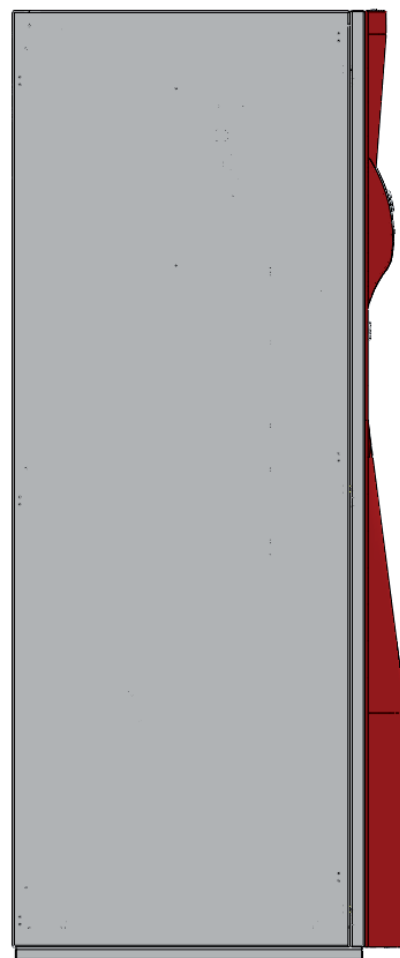

Side view

DIMENSIONS

Air Source Heat Pump-Split Design | Basic Comfort Series

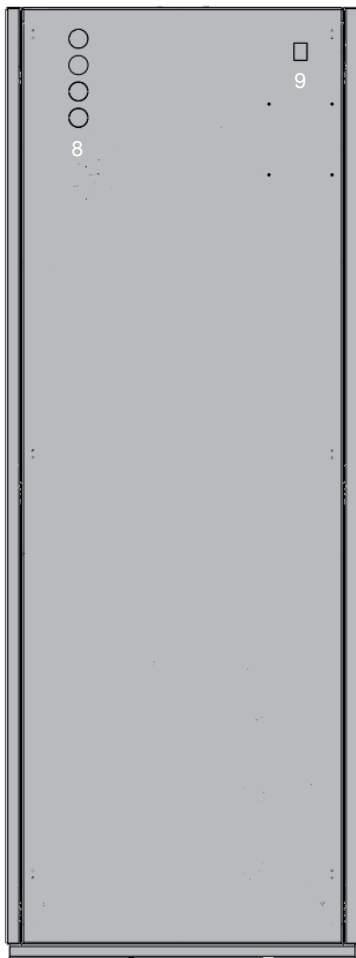

Rear view

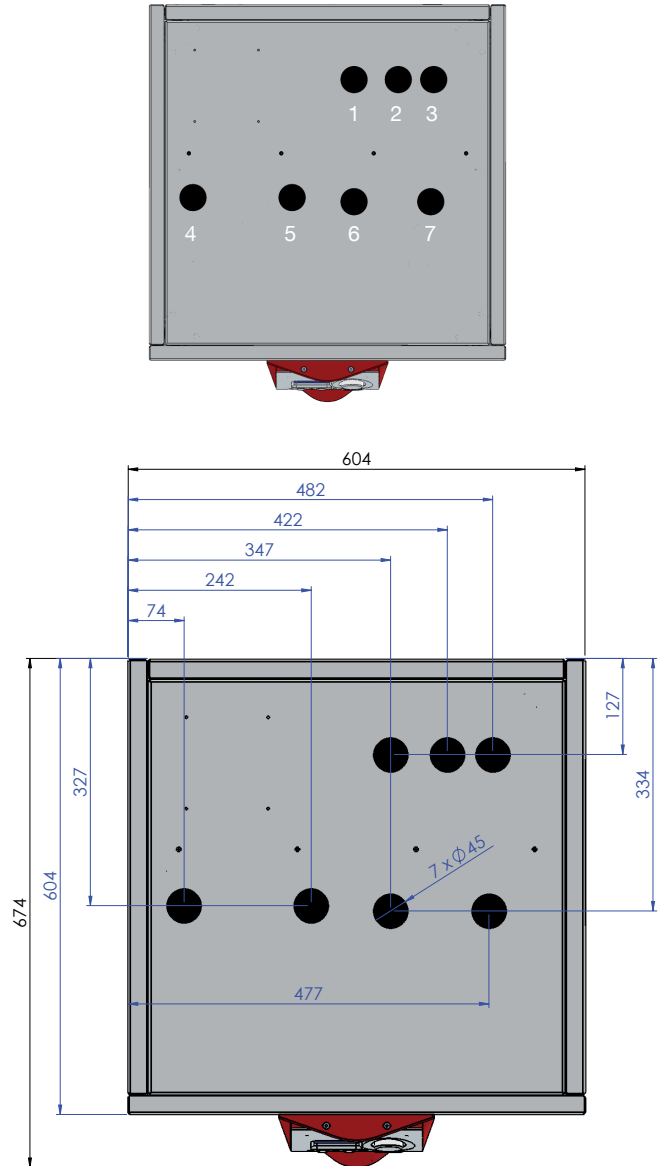

Dimensions (mm)

- 1 -
- 2 Suction line - 18 mm
- 3 Pressure line - 12 mm
- 4 Outlet heating - 1" ET
- 5 Outlet DHW - 1" ET
- 6 Inlet heating - 1" ET
- 7 Inlet DHW - 1" ET
- 8 Cable feedthrough
- 9 On/Off switch
- 10 Control unit

TECHNICAL DATA SHEET HP06L-K-BC

Air Source Heat Pump-Split Design | Basic Comfort Series

Performance data ¹⁾ EN255 Δ 10 K			
	A-7W35	A2W35	A2W50
Heating capacity	4,77 kW	6,31 kW	5,60 kW
Cooling capacity	3,28 kW	4,81 kW	3,56 kW
Input	1,49 kW	1,50 kW	2,04 kW
COP	3,21	4,22	2,74

Performance data ¹⁾ EN14511 Δ 5 K			
	A-7W35	A2W35	A2W50
Heating capacity	4,94 kW	6,51 kW	5,81 kW
Cooling capacity	3,35 kW	4,91 kW	3,63 kW
Input	1,59 kW	1,60 kW	2,19 kW
COP	3,10	4,07	2,66

Compressor	
Type	Scroll
Speed RPM	2900 min ⁻¹
Max. input power	3,0 kW
Stall current	32 A
Oil amount	1,3 l

Outdoor evaporator (required)
See data sheet HPLV06/08/10-BC

Condenser & subcooler / Heating	
Type	Plate heat exchanger
Material	Stainless steel / CU soldered
Flow amount ²⁾	1,2 m ³ /h
Pressure loss	0,9 mWs
Temperature difference	5 K
Operating pressure*	0,51 bar
Tested pressure	45 bar

Refrigerant cycle	
Working fluid	R410a
Fill amount with 10 m split line	7,3 kg

Electric	
Voltage	400 V
Frequency	50 Hz
Time lag fuse	3 x 10 A
Max. compressor operating current	5,5 A
Starting current	32 A
Starting current with soft-starter	21,3 A

Acoustic pressure level	
1 m distance	45 dB(A)

Connections, dimensions	
Heating outlet and inlet	1" ET
Pressure line / Suction line	12/18 mm
Height x Width x Depth	1.625x604x674 mm
Weight	165 kg

Operating limit values	
Max. operating water pressure	10 bar
Max. operating refrigerant cycle	40 bar
Max. heat outlet temperature	60 °C at 0 °C OT

¹⁾ Performance specifications:
 A = Outdoor (air) temperature in °C
 W = Heating water temperature in °C

Defrost loss has been calculated.

²⁾ Minimum flow must be observed!

* In conjunction with a Heliotherm hydraulic block.

0,25 kW/person are to be calculated to the heating load for DHW preparation.

EN 12900 tolerance results are valid for the above mentioned performance data.

TECHNICAL DATA SHEET HP06L-K-BC

Air Source Heat Pump-Split Design | Basic Comfort Series

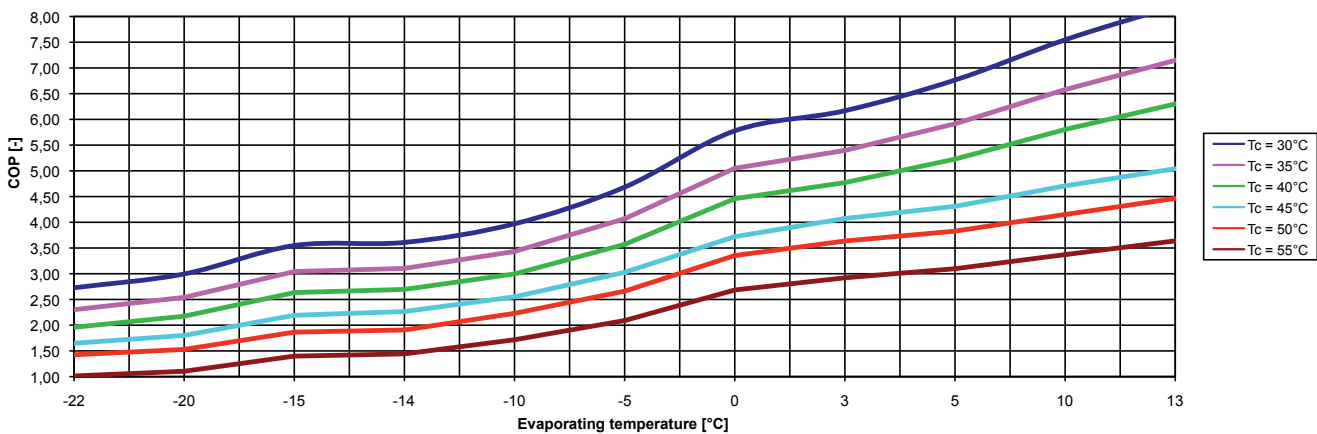
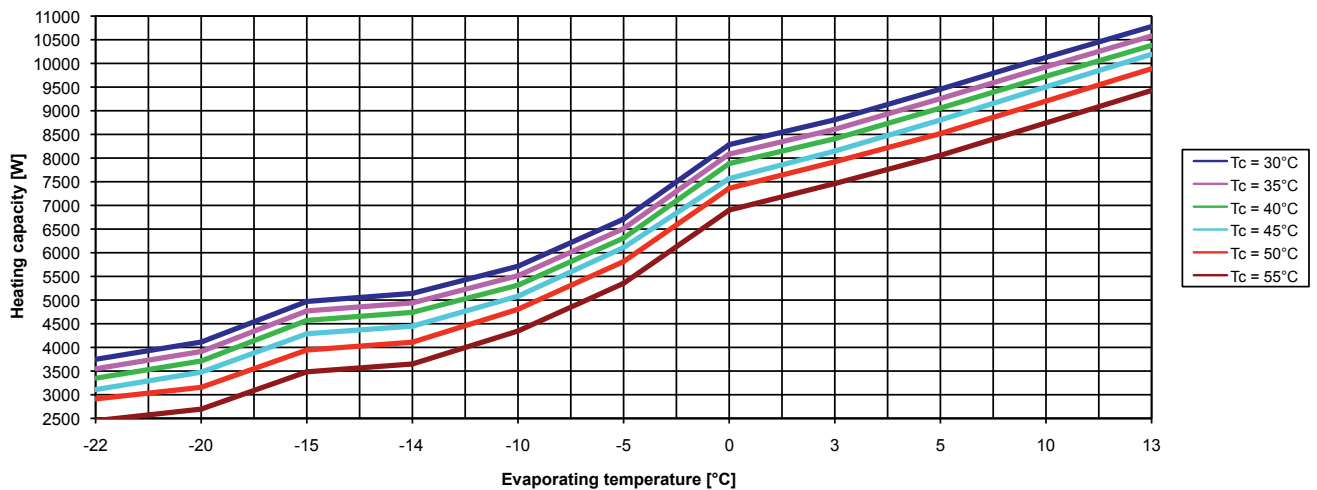

EN 12900 tolerance results are valid for the above mentioned performance data.
All performance data is according to EN14511.

TECHNICAL DATA SHEET HP08L-K-BC

Air Source Heat Pump-Split Design | Basic Comfort Series

Performance data ¹⁾ EN255 Δ 10 K			
	A-7W35	A2W35	A2W50
Heating capacity	6,06 kW	7,73 kW	6,88 kW
Cooling capacity	4,24 kW	5,91 kW	4,49 kW
Input	1,81 kW	1,82 kW	2,39 kW
COP	3,34	4,24	2,88

Performance data ¹⁾ EN14511 Δ 5 K			
	A-7W35	A2W35	A2W50
Heating capacity	6,27 kW	7,98 kW	7,14 kW
Cooling capacity	4,33 kW	6,03 kW	4,58 kW
Input	1,94 kW	1,95 kW	2,56 kW
COP	3,23	4,09	2,79

Compressor	
Type	Scroll
Speed RPM	2900 min ⁻¹
Max. input power	3,7 kW
Stall current	35 A
Oil amount	1,3 l

Outdoor evaporator (required)
See data sheet HPLV06/08/10-BC

Condenser & subcooler / Heating	
Type	Plate heat exchanger
Material	Stainless steel / CU soldered
Flow amount ²⁾	1,6 m ³ /h
Pressure loss	1,5 mWs
Temperature difference	5 K
Operating pressure*	0,38 bar
Tested pressure	45 bar

Refrigerant cycle	
Working fluid	R410a
Fill amount with 10 m split line	7,5 kg

Electric	
Voltage	400 V
Frequency	50 Hz
Time lag fuse	3 x 16 A
Max. compressor operating current	6 A
Starting current	35 A
Starting current with soft-starter	23,3 A

Acoustic pressure level	
1 m distance	45 dB(A)

Connections, dimensions	
Heating outlet and inlet	1" ET
Pressure line / Suction line	12/18 mm
Height x Width x Depth	1.625x604x674 mm
Weight	170 kg

Operating limit values	
Max. operating water pressure	10 bar
Max. operating refrigerant cycle	40 bar
Max. heat outlet temperature	60 °C at 0 °C OT

¹⁾ Performance specifications:
 A = Outdoor (air) temperature in °C
 W = Heating water temperature in °C

Defrost loss has been calculated.

²⁾ Minimum flow must be observed!

* In conjunction with a Heliotherm hydraulic block.

0,25 kW/person are to be calculated to the heating load for DHW preparation.

EN 12900 tolerance results are valid for the above mentioned performance data.

TECHNICAL DATA SHEET HP08L-K-BC

Air Source Heat Pump-Split Design | Basic Comfort Series

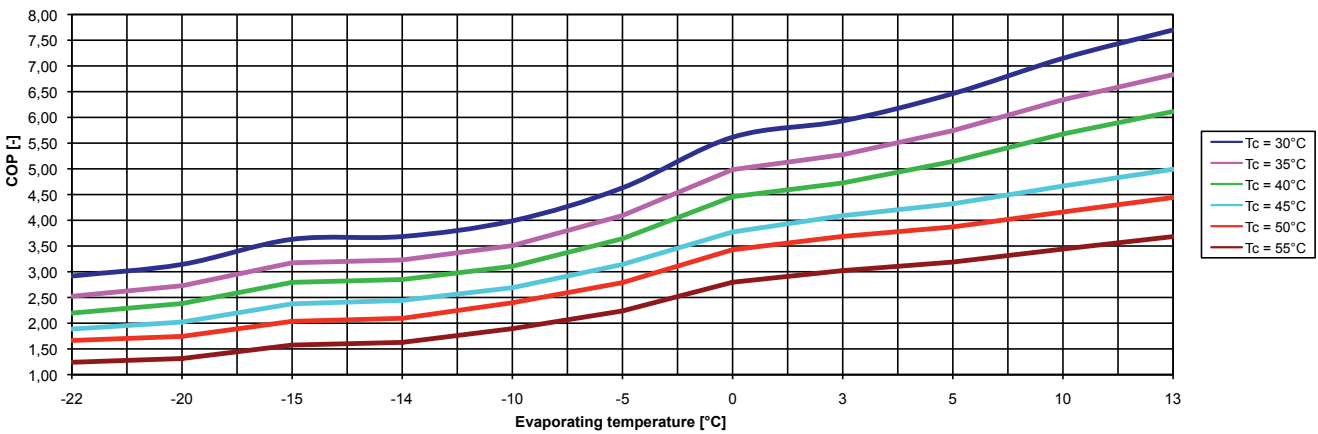
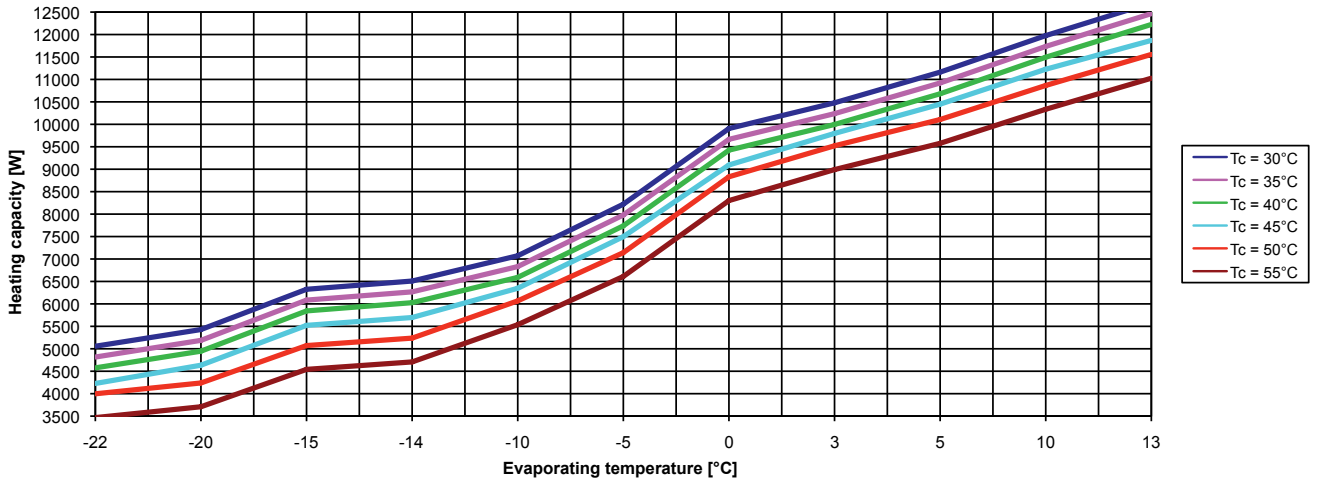

EN 12900 tolerance results are valid for the above mentioned performance data.
All performance data is according to EN14511.

TECHNICAL DATA SHEET HP10L-K-BC

Air Source Heat Pump-Split Design | Basic Comfort Series

Performance data ¹⁾ EN255 Δ 10 K			
	A-7W35	A2W35	A2W50
Heating capacity	7,54 kW	9,64 kW	8,47 kW
Cooling capacity	5,29 kW	7,38 kW	5,54 kW
Input	2,25 kW	2,26 kW	2,93 kW
COP	3,35	4,26	2,89

Performance data ¹⁾ EN14511 Δ 5 K			
	A-7W35	A2W35	A2W50
Heating capacity	7,80 kW	9,95 kW	8,79 kW
Cooling capacity	5,39 kW	7,53 kW	5,65 kW
Input	2,41 kW	2,42 kW	3,14 kW
COP	3,24	4,11	2,80

Compressor	
Type	Scroll
Speed RPM	2900 min ⁻¹
Max. input power	4,1 kW
Stall current	48 A
Oil amount	1,3 l

Outdoor evaporator (required)
See data sheet HPLV06/08/10-BC

Condenser & subcooler / Heating	
Type	Plate heat exchanger
Material	Stainless steel / CU soldered
Flow amount ²⁾	2,1 m ³ /h
Pressure loss	1,6 mWs
Temperature difference	5 K
Operating pressure*	0,31 bar
Tested pressure	45 bar

Refrigerant cycle	
Working fluid	R410a
Fill amount with 10 m split line	7,9 kg

Electric	
Voltage	400 V
Frequency	50 Hz
Time lag fuse	3 x 16 A
Max. compressor operating current	8 A
Starting current	48 A
Starting current with soft-starter	32 A

Acoustic pressure level	
1 m distance	45 dB(A)

Connections, dimensions	
Heating outlet and inlet	1" ET
Pressure line / Suction line	12/18 mm
Height x Width x Depth	1.625x604x674 mm
Weight	170 kg

Operating limit values	
Max. operating water pressure	10 bar
Max. operating refrigerant cycle	40 bar
Max. heat outlet temperature	60 °C at 0 °C OT

¹⁾ Performance specifications:

A = Outdoor (air) temperature in °C
W = Heating water temperature in °C

Defrost loss has been calculated.

²⁾ Minimum flow must be observed!

* In conjunction with a Heliotherm hydraulic block.

0,25 kW/person are to be calculated to the heating load for DHW preparation.

EN 12900 tolerance results are valid for the above mentioned performance data.

TECHNICAL DATA SHEET HP10L-K-BC

Air Source Heat Pump-Split Design | Basic Comfort Series

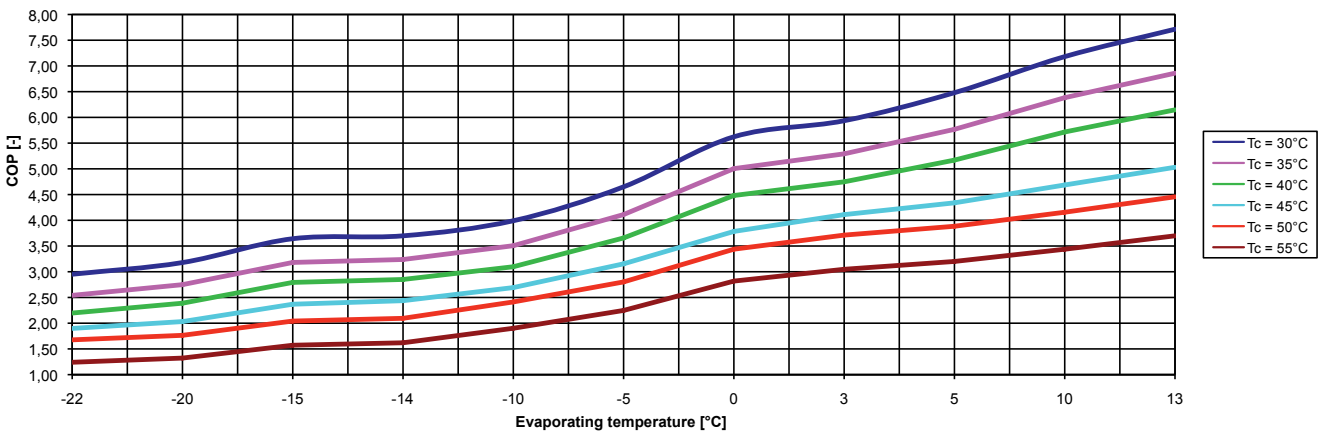
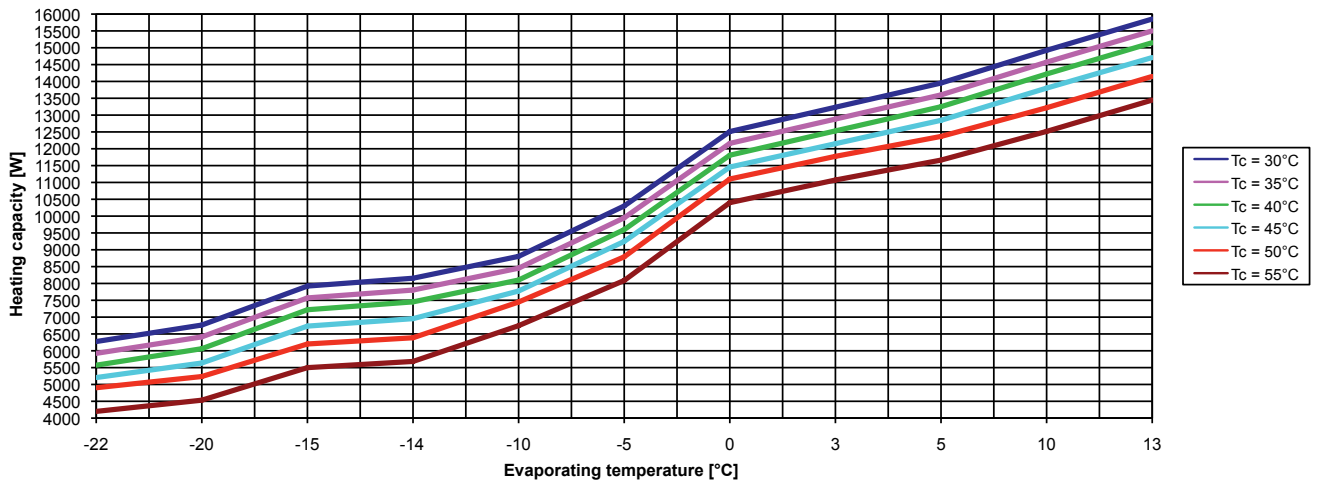

EN 12900 tolerance results are valid for the above mentioned performance data.
All performance data is according to EN14511.

TECHNICAL DATA SHEET HP12L-K-BC

Air Source Heat Pump-Split Design | Basic Comfort Series

Performance data ¹⁾ EN255 Δ 10 K			
	A-7W35	A2W35	A2W50
Heating capacity	9,39 kW	12,15 kW	10,89 kW
Cooling capacity	6,57 kW	9,28 kW	7,09 kW
Input	2,82 kW	2,87 kW	3,79 kW
COP	3,33	4,23	2,87

Performance data ¹⁾ EN14511 Δ 5 K			
	A-7W35	A2W35	A2W50
Heating capacity	9,72 kW	12,54 kW	11,30 kW
Cooling capacity	6,70 kW	9,47 kW	7,24 kW
Input	3,02 kW	3,07 kW	4,06 kW
COP	3,22	4,08	2,78

Compressor	
Type	Scroll
Speed RPM	2900 min ⁻¹
Max. input power	4,8 kW
Stall current	64 A
Oil amount	1,7 l

Outdoor evaporator (required)
See data sheet HPLV12/14-BC

Condenser & subcooler / Heating	
Type	Plate heat exchanger
Material	Stainless steel / CU soldered
Flow amount ²⁾	2,4 m ³ /h
Pressure loss	2,1 mWs
Temperature difference	5 K
Operating pressure*	0,46 bar
Tested pressure	45 bar

Refrigerant cycle	
Working fluid	R410a
Fill amount with 10 m split line	9,4 kg

Electric	
Voltage	400 V
Frequency	50 Hz
Time lag fuse	3 x 16 A
Max. compressor operating current	10 A
Starting current	64 A
Starting current with soft-starter	42,6 A

Acoustic pressure level	
1 m distance	45 dB(A)

Connections, dimensions	
Heating outlet and inlet	1" ET
Pressure line / Suction line	12/18 mm
Height x Width x Depth	1.625x604x674 mm
Weight	175 kg

Operating limit values	
Max. operating water pressure	10 bar
Max. operating refrigerant cycle	40 bar
Max. heat outlet temperature	60 °C at 0 °C OT

¹⁾ Performance specifications:

A = Outdoor (air) temperature in °C
W = Heating water temperature in °C

Defrost loss has been calculated.

²⁾ Minimum flow must be observed!

* In conjunction with a Heliotherm hydraulic block.

0,25 kW/person are to be calculated to the heating load for DHW preparation.

EN 12900 tolerance results are valid for the above mentioned performance data.

TECHNICAL DATA SHEET HP12L-K-BC

Air Source Heat Pump-Split Design | Basic Comfort Series

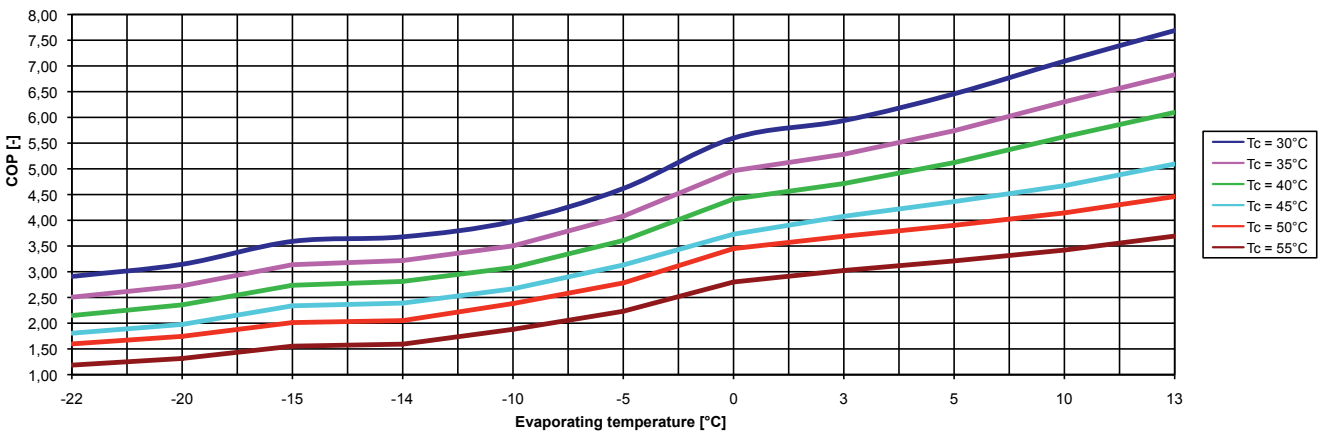
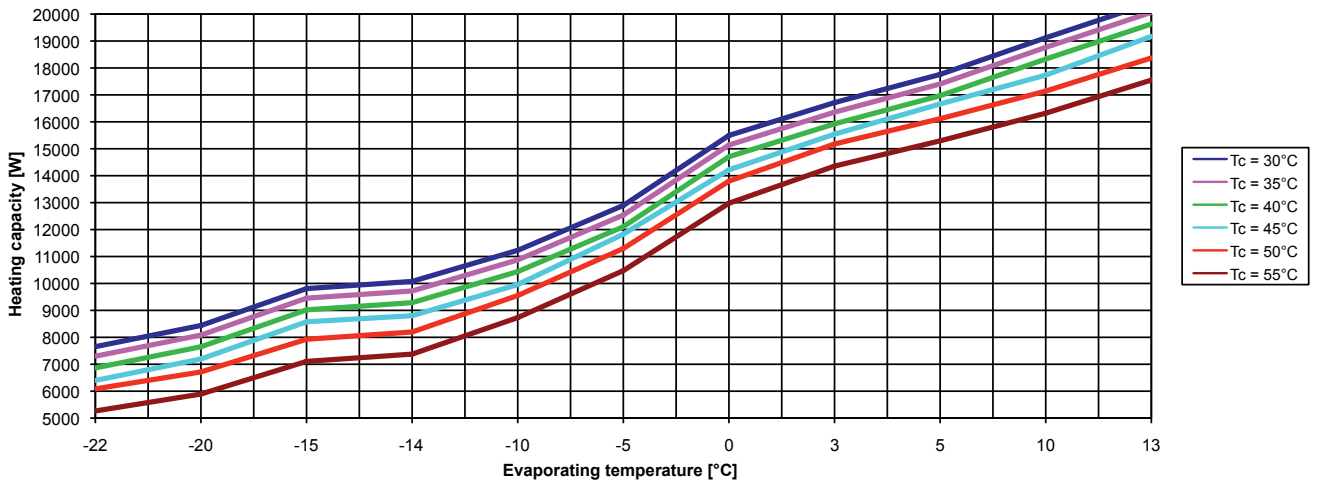

EN 12900 tolerance results are valid for the above mentioned performance data.
All performance data is according to EN14511.

TECHNICAL DATA SHEET HPP14L-K-BC

Air Source Heat Pump-Split Design | Basic Comfort Series

Performance data ¹⁾ EN255 Δ 10 K			
	A-7W35	A2W35	A2W50
Heating capacity	11,41 kW	14,87 kW	13,10 kW
Cooling capacity	7,96 kW	11,33 kW	8,50 kW
Input	3,45 kW	3,53 kW	4,60 kW
COP	3,31	4,21	2,85

Performance data ¹⁾ EN14511 Δ 5 K			
	A-7W35	A2W35	A2W50
Heating capacity	11,81 kW	15,34 kW	13,59 kW
Cooling capacity	8,12 kW	11,56 kW	8,67 kW
Input	3,69 kW	3,78 kW	4,92 kW
COP	3,20	4,06	2,76

Compressor	
Type	Scroll
Speed RPM	2900 min ⁻¹
Max. input power	5,9 kW
Stall current	74 A
Oil amount	1,7 l

Outdoor evaporator (required)
See data sheet HPLV12/14-BC

Condenser & subcooler / Heating	
Type	Plate heat exchanger
Material	Stainless steel / CU soldered
Flow amount ²⁾	3,2 m ³ /h
Pressure loss	2,6 mWs
Temperature difference	5 K
Operating pressure*	0,38 bar
Tested pressure	45 bar

Refrigerant cycle	
Working fluid	R410a
Fill amount with 10 m split line	9,8 kg

Electric	
Voltage	400 V
Frequency	50 Hz
Time lag fuse	3 x 16 A
Max. compressor operating current	12,2 A
Starting current	74 A
Starting current with soft-starter	49,3 A

Acoustic pressure level	
1 m distance	46 dB(A)

Connections, dimensions	
Heating outlet and inlet	1" ET
Pressure line / Suction line	12/18 mm
Height x Width x Depth	1.625x604x674 mm
Weight	175 kg

Operating limit values	
Max. operating water pressure	10 bar
Max. operating refrigerant cycle	40 bar
Max. heat outlet temperature	60 °C at 0 °C OT

¹⁾ Performance specifications:

A = Outdoor (air) temperature in °C
W = Heating water temperature in °C

Defrost loss has been calculated.

²⁾ Minimum flow must be observed!

* In conjunction with a Heliotherm hydraulic block.

0,25 kW/person are to be calculated to the heating load for DHW preparation.

EN 12900 tolerance results are valid for the above mentioned performance data.

TECHNICAL DATA SHEET HPP14L-K-BC

Air Source Heat Pump-Split Design | Basic Comfort Series

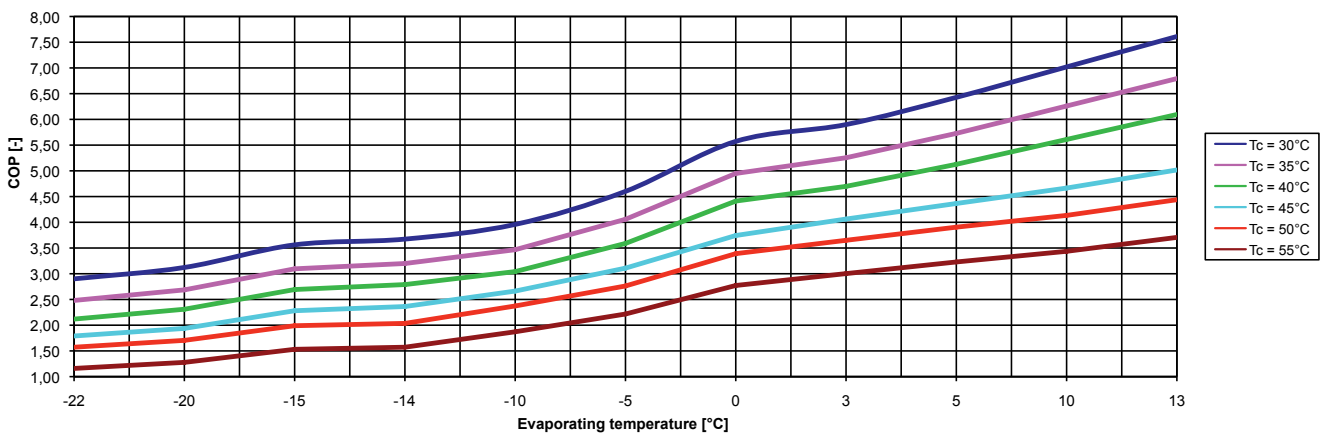
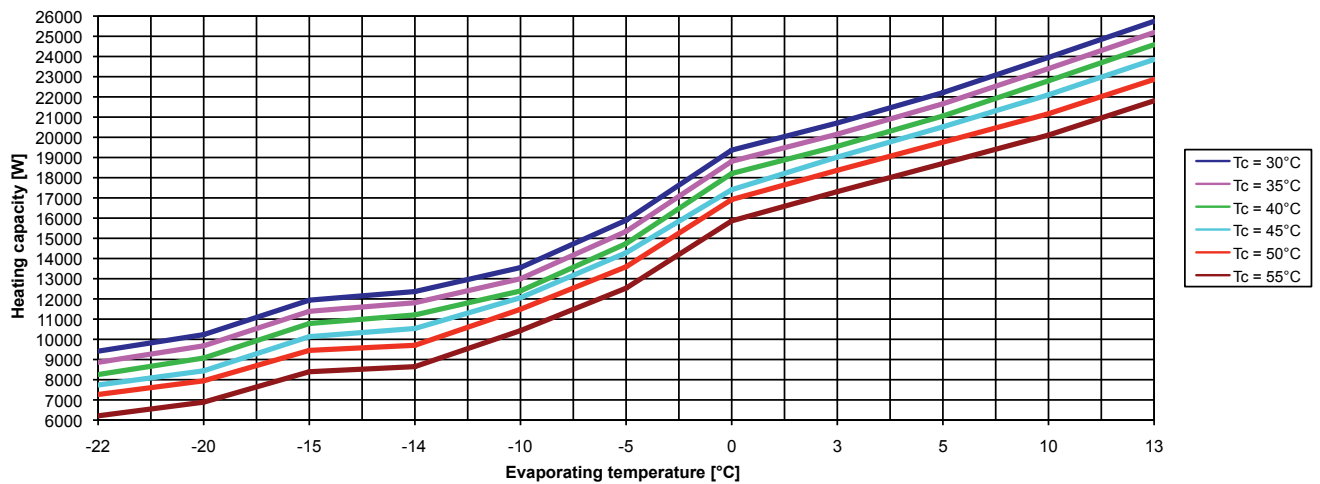

EN 12900 tolerance results are valid for the above mentioned performance data.
All performance data is according to EN14511.

TECHNICAL DATA SHEET HPLV06/08/10-BC

Air Source Heat Pump-Split Design | Basic Comfort Series

General	
Type	Fin evaporator
Material	Copper/aluminium
Amount	1
Area	70 m ²
Air quantity	5.500 m ³ /h
max. ext. static pressure loss	15 Pa
Ventilator	Axial
Range of use	-15 °C/+30 °C
Tested pressure	30 bar
Speed RPM	530 r/min
Nitrogen pressure	10 bar

Refrigerant cycle	
Working fluid	R410a
Max. operating refrigerant cycle	27 bar

Electric	
Voltage	400 V
Frequency	50 Hz
Power consumption	0,38 A
Ventilator input	190 W
Fuse	Thermorelais

Connections, dimensions	
Pressure line / Suction line	12/28 mm

Weight	
HPLV06/08/10-BC	125 kg

Acoustic pressure level a.t. DIN 18005	
1 m distance	55 dB(A)
5 m distance	41 dB(A)
10 m distance	32 dB(A)

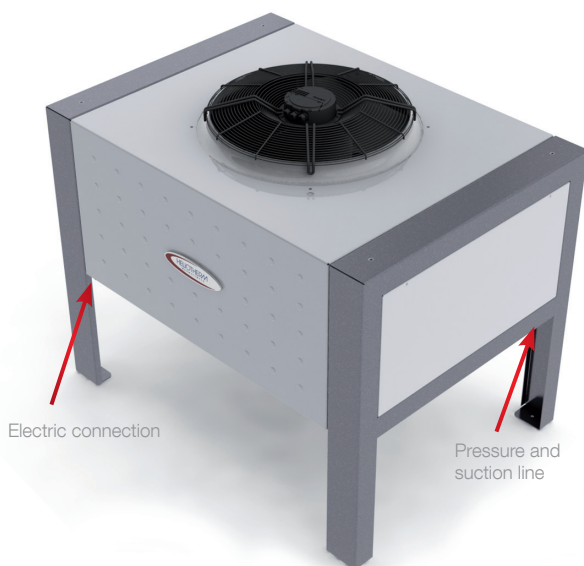
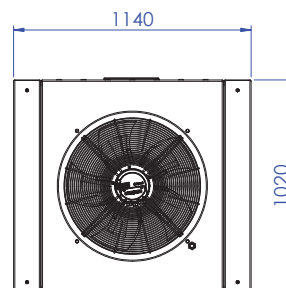
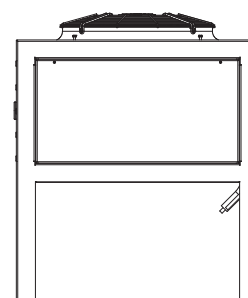
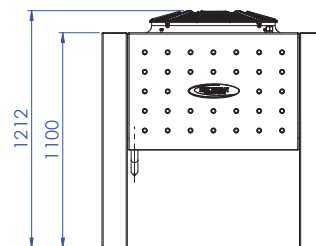

TECHNICAL DATA SHEET HPLV12/14-BC

Air Source Heat Pump-Split Design | Basic Comfort Series

General	
Type	Fin evaporator
Material	Copper/aluminium
Amount	1
Area	90 m ²
Air quantity	5.500 m ³ /h
max. ext. static pressure loss	15 Pa
Ventilator	Axial
Range of use	-15 °C/+30 °C
Tested pressure	30 bar
Speed RPM	530 r/min
Nitrogen pressure	10 bar

Refrigerant cycle	
Working fluid	R410a
Max. operating refrigerant cycle	27 bar

Electric	
Voltage	400 V
Frequency	50 Hz
Power consumption	0,38 A
Ventilator input	190 W
Fuse	Thermorelais

Connections, dimensions	
Pressure line / Suction line	14/35 mm

Weight	
HPLV12/14-BC	133 kg

Acoustic pressure level a.t. DIN 18005	
1 m distance	55 dB(A)
5 m distance	41 dB(A)
10 m distance	32 dB(A)

